

Install the 5 mm and 6 mm carburetor connecting bolts through the carburetors.

NOTE:

Before tightening the carburetor connecting nuts, check there is no clearance between each of the carburetor joints.

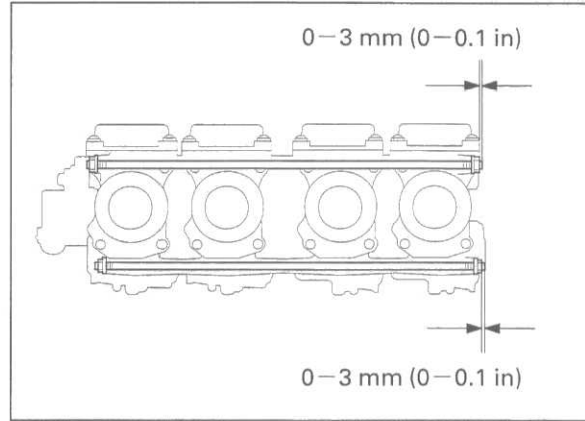

Tighten each connecting nuts gradually and alternately, be sure the bolt thread projections are equal height.

Hold the nut and tighten the nut on other side to the specified torque.

TORQUE:

5 mm nut: 5 N·m (0.5 kgf·m , 3.6 lbf·ft)

6 mm nut: 10 N·m (1.0 kgf·m , 7 lbf·ft)

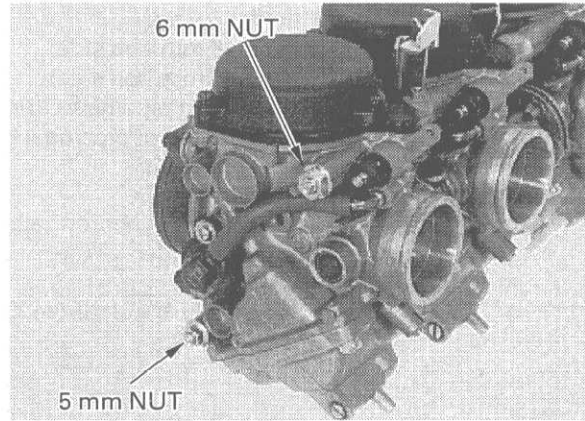

Install the plastic collars onto the No.2 and No.4 carburetor bodies.

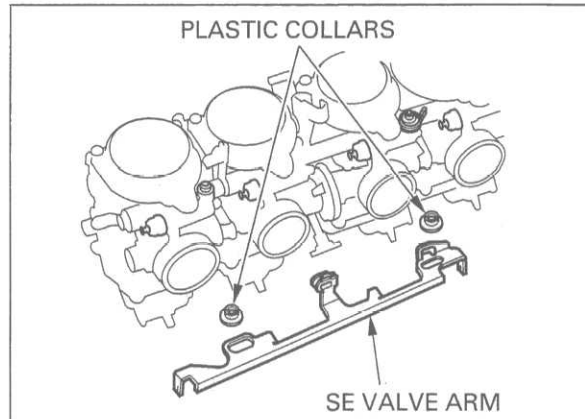

Install the SE valve arm aligning its ends with the SE valve heads.

