

CRANKSHAFT/TRANSMISSION/BALANCER

Apply grease to the threads of rear balancer timing hole cap.

Check the O-ring is in good condition, install the rear balancer timing hole cap.

Tighten the cap to the specified torque.

TORQUE: 7 N·m (0.7 kgf·m , 5.1 lbf·ft)

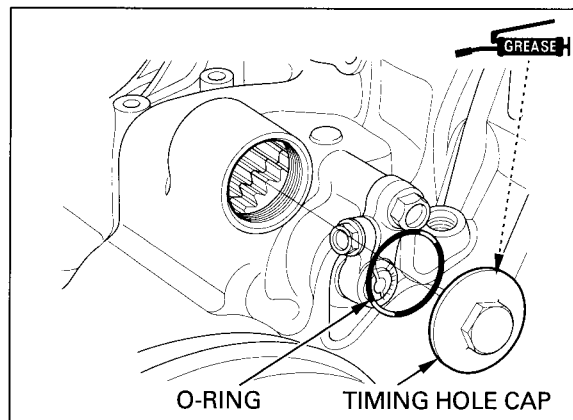

BACKLASH ADJUSTMENT

NOTE:

Adjust the backlash while the engine is cold (below 35 °C/95 °F) and the engine stopped.

Remove the balancer shaft holder pinch bolts and the idle gear shaft holder pinch bolt.

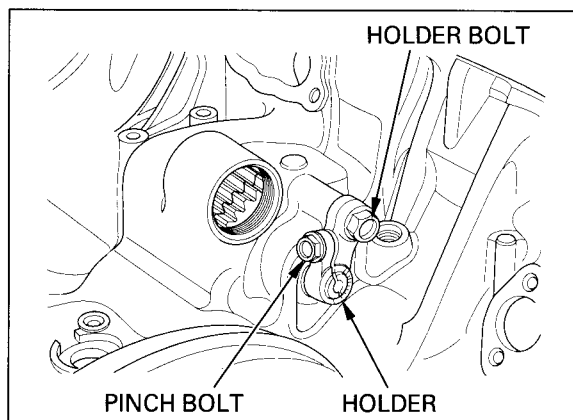

Turn the rear balancer idle gear shaft counterclockwise until the resistance is felt, then back it off one graduation using the punch mark as a measure.

CAUTION:

Excessive force can cause a balancer gear, bearing and shaft damage. Do not turn the shaft more than necessary.

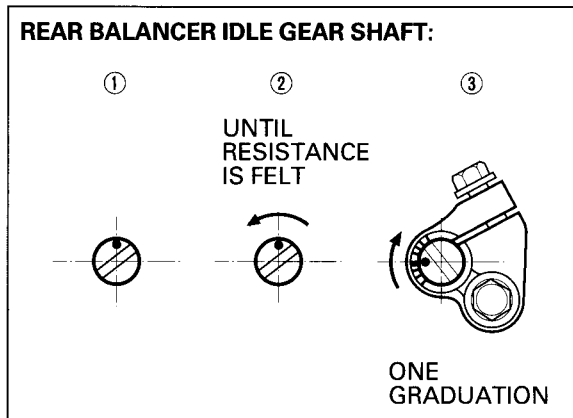

Turn the rear balancer shaft counterclockwise until the resistance is felt, then back it off one graduation using the punch mark as a measure.

